



Performance Pump & Equipment

Performance Pump & Equipment Company Limited
Unit 12, Tattenham Works, Hindley Green, Wigan WN2 4SZ

enquiries@performancepump.co.uk
www.performancepumps.co.uk

Tel: 01942 259621
Fax: 01942 258549

MINEX 50Hz Electrical submersible drainage pump
Product Code PD001

A premium quality electric submersible contractors pump, built with the toughest materials to ensure reliability in the most hazardous applications, powered by highly efficient electric motors ensuring minimum energy costs and maximum performance, fitted with high quality mechanical seals contained within an oil filled housing to ensure run dry fault free operation

Typical Applications

- General site work and excavation dewatering
- Tank emptying and cleaning
- Waste water and sewer applications
- Booster pumps
- Water transfer
- Flood alleviation
- Emergency pumping
- Industrial processes
- Quarries and mines
- Plus many more

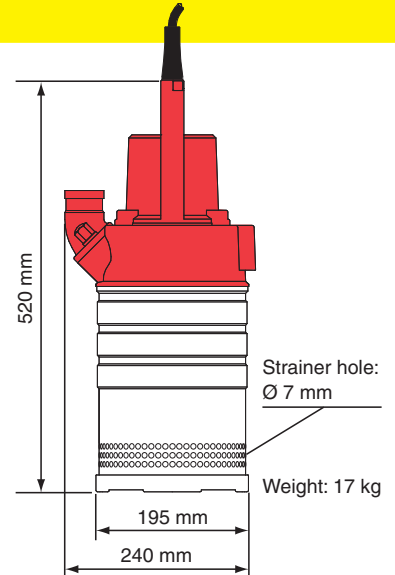

Pump Specification

Pump types	— Single phase — 3 - phase												
Shaft speed	2800 r.p.m. 2800 r.p.m.												
Rated output	0.9kW 1.6kW												
Max. power cons	1.2kW 1.9kW												
Rated current A at	<table border="0"> <tr> <td>110V</td> <td>10</td> <td></td> </tr> <tr> <td>230V</td> <td>5.5</td> <td>6.5</td> </tr> <tr> <td>400V</td> <td></td> <td>3.7</td> </tr> <tr> <td>500V</td> <td></td> <td>3.0</td> </tr> </table> <i>Other voltages on request</i>	110V	10		230V	5.5	6.5	400V		3.7	500V		3.0
110V	10												
230V	5.5	6.5											
400V		3.7											
500V		3.0											
Power cable	H07RN-F length 20 m 3x1.5mm², (230V), 3x4mm² (110V) 4x4mm²												
Discharge connection	2", hose, BSP or NPT												
Limitations	Max. submersion depth: 20m Max. liquid temperature: 40°C Max. liquid density: 1100 kg/m ³ pH of the liquid: 5-8												

Performance statistics

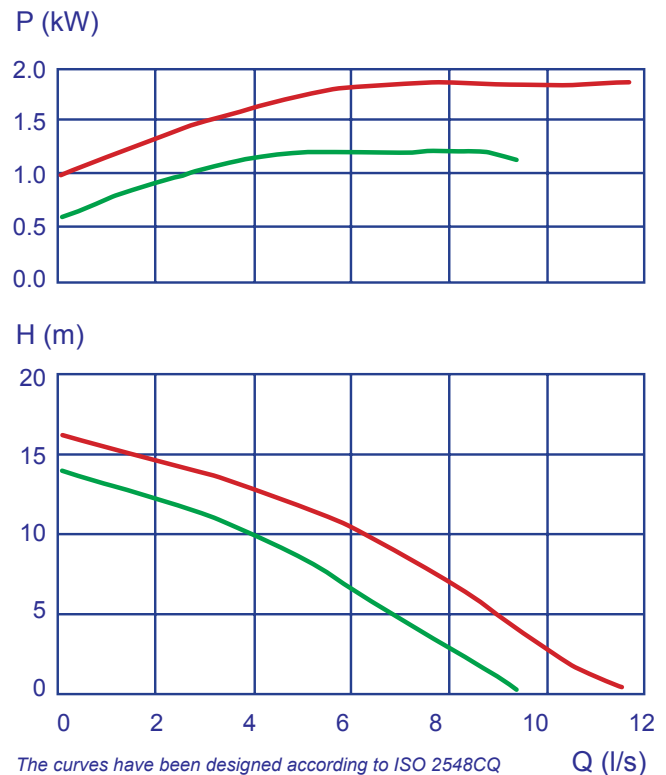

Hire Hotline: 0844 736 5964